

# MYC-Y6ULX Product Manual

Version 1.4

**Version History**

<b>Version</b>	<b>Description</b>	<b>Date</b>
V1.0	Initial version	01-Nov-2017
V1.1	Add chapter 6.2 and chapter 8	09-Mar-2018
V1.2	Changed figure 8.1 and figure 8.2	20-Apr-2018
V1.3	Update chapter 8 about booting config	18-May-2018
V1.4	Update design of mini system for MYC-YULX	15-Oct-2018

# Table of Contents

<b>Table of Contents</b> .....	<b>3</b>
<b>1.Product Abstract</b> .....	<b>4</b>
<b>2. Hardware Characteristics</b> .....	<b>8</b>
2.1 i.MX 6ULL Characteristics.....	8
2.2 Board Resource.....	11
2.3 Expansion Connector Resource.....	12
<b>3. Interfaces</b> .....	<b>13</b>
3.1 Pin Assignment.....	错误! 未定义书签。
3.2 Pin list.....	13
<b>4. Hardware Design</b> .....	<b>14</b>
4.1 Power supply.....	14
4.2 Clock Resources.....	15
4.3 DDR3L SDRAM.....	15
4.4 eMMC Memory.....	16
4.5 NAND Flash Memory.....	17
4.6 Ethernet.....	18
<b>5. Electronic Characteristics</b> .....	<b>20</b>
5.1 Operating Temperature.....	20
5.2 Power Supply Characteristics.....	20
5.3 GPIO DC Characteristics.....	21
<b>6. Mechanical Characteristics</b> .....	<b>22</b>
6.1 Mechanical Data.....	22
6.2 Recommender PCB Footprint.....	22
<b>7. Development Kits</b> .....	<b>24</b>
<b>8. Schematic design information</b> .....	<b>25</b>
8.1 Boot information.....	25
8.2 Base system design reference.....	26
8.3 Design advice.....	28

# 1.Product Abstract

The MYC-Y6ULX is a high-performance low-cost CPU module designed by MYIR. It is based on NXP i.MX6UL/6ULL processor family which features the most efficient ARM Cortex-A7 core. Each processor in this family provides various memory interfaces, including 16-bit LPDDR2, DDR3, DDR3L, raw and managed NAND flash, NOR flash, eMMC, Quad SPI and a wide range of other interfaces for connecting peripherals. MYIR provides rich software resources and detailed documents with the board including user manuals, schematic of the base board, peripheral drivers, BSP source packages, development tools and other related information.



Figure 1.1 MYC-Y6ULX

The i.MX6UL/6ULL application processor on the MYC-Y6ULX board provides multiple compatible options of Y0, Y1, Y2, G0, G1, G2 and G3 sub families. MYIR provides the following three part number by default.

产品型号	MYC-Y6ULY2-256N25 6D-50-C	MYC-Y6ULY2-256N25 6D-50-I	MYC-Y6ULY2-4E512 D-50-C	MYC-Y6ULY2-4E512 D-50-I
主芯片	MCIMX6Y2DVM05AA	MCIMX6Y2CVM05AB	MCIMX6Y2DVM05AA	MCIMX6Y2CVM05AB
工作温度	0°C - +70°C	-40°C - +85°C	0°C - +70°C	-40°C - +85°C
内存	256MB DDR	256MB DDR	512MB DDR	512MB DDR
存储器	256MB NandFlash	256MB NandFlash	4GB EMMC	4GB EMMC

Table 1.1 Part Number of MYC-Y6ULX (default configurations)

MYIR offers customization on optional CPU and memory size configuration in bulk orders.

The differences between these chips are as follows.

Feature	MCIMX6G0	MCIMX6G1	MCIMX6G2	MCIMX6G3
<b>Speed</b>	528 MHz	500 MHz, 700 MHz	528 MHz, 700 MHz	528 MHz
<b>Cache</b>	32 KB-I, 32 KB-D	32 KB-I, 32 KB-D 128 KB L2	32 KB-I, 32 KB-D 128 KB L2	32 KB-I, 32 KB-D 128 KB L2
<b>OCRAM</b>	128 KB	128 KB	128 KB	128 KB
<b>DRAM</b>	16-bit LP-DDR2, DDR3/DDR3L	16-bit LP-DDR2, DDR3/DDR4L	16-bit LP-DDR2, DDR3/DDR5L	16-bit LP-DDR2, DDR3/DDR6L
<b>eFuse</b>	512-bit	1024-bit	1536-bit	2048-bit
<b>NAND (BCH40)</b>	Yes	Yes	Yes	Yes
<b>EBI</b>	Yes	Yes	Yes	Yes
<b>Ethernet</b>	10/100-Mbit/s x 1	10/100-Mbit/s x 1	10/100-Mbit/s x 2	10/100-Mbit/s x 2
<b>USB</b>	OTG, HS/FS x 1	OTG, HS/FS x 2	OTG, HS/FS x 2	OTG, HS/FS x 2
<b>CAN</b>	0	1	2	2
<b>Security</b>	Basic	TRNG, Crypto Engine (AES/TDES/SHA), Secure Boot	TRNG, Crypto Engine (AES/TDES/SHA), Secure Boot	TRNG, Crypto Engine (AES with DPA/TDES/SHA/RSA), Secure Boot, tamper monitor,

				PCI4.0 pre-certification, OTF DRAM encryption
<b>Graphic</b>	None	None	PxP	PxP
<b>CSI</b>	None	None	24-bit Parallel CSI	24-bit Parallel CSI
<b>LCD</b>	None	None	24-bit Parallel LCD	24-bit Parallel LCD
<b>Quad SPI</b>	1	1	1	1
<b>SDIO</b>	2	2	2	2
<b>UART</b>	4	8	8	8
<b>I2C</b>	2	4	4	4
<b>SPI</b>	2	4	4	4
<b>I2S/SAI</b>	1	3	3	3
<b>S/PDIF</b>	1	1	1	1
<b>Timer/PWM</b>	Timer x 2, PWM x 4	Timer x 4, PWM x 8	Timer x 4, PWM x 8	Timer x 4, PWM x 8
<b>12-bit ADC</b>	1 x 10-ch.	1 x 10-ch.	2 x 10-ch.	2 x 10-ch.

**Table 1.2 i.MX 6UL Processor Resource Comparison**

<b>Feature</b>	<b>MCIMX6Y0</b>	<b>MCIMX6Y1</b>	<b>MCIMX6Y2</b>
<b>Core</b>	ARM® Cortex-A7	ARM® Cortex-A7	ARM® Cortex-A7
<b>Speed</b>	528 MHz	528 MHz	528/800/900 MHz
<b>Cache</b>	32 KB-I, 32 KB-D	32 KB-I, 32 KB-D 128 KB L2	32 KB-I, 32 KB-D 128 KB L2
<b>OCRAM</b>	128 KB	128 KB	128 KB
<b>DRAM</b>	16-bit LP-DDR2, DDR3/DDR3L	16-bit LP-DDR2, DDR3/DDR4L	16-bit LP-DDR2, DDR3/DDR5L
<b>eFuse</b>	256-bit	256-bit	256-bit
<b>NAND (BCH40)</b>	Yes	Yes	Yes
<b>EBI</b>	Yes	Yes	Yes

<b>Ethernet</b>	10/100-Mbit/s x 1	10/100-Mbit/s x 1	10/100-Mbit/s x 2
<b>USB</b>	OTG, HS/FS x 1	OTG, HS/FS x 2	OTG, HS/FS x 2
<b>CAN</b>	0	1	2
<b>Graphic</b>	None	None	PxP
<b>CSI</b>	None	None	16-bit Parallel CSI
<b>LCD</b>	None	None	24-bit Parallel LCD
<b>Quad SPI</b>	1	1	1
<b>SDIO</b>	2	2	2
<b>UART</b>	4	8	8
<b>I2C</b>	2	4	4
<b>SPI</b>	2	4	4
<b>I2S/SAI</b>	1	3	3
<b>ESAI</b>	1	1	1
<b>S/PDIF</b>	1	1	1
<b>Timer/PWM</b>	Timer x 2, PWM x 4	Timer x 4, PWM x 8	Timer x 4, PWM x 8
<b>12-bit ADC</b>	1 x 10-ch.	1 x 10-ch.	2 x 10-ch.
<b>Security</b>	None	AES-128, HAB	AES-128, HAB
<b>Temperature</b>	-40°C to 105°C (Tj)	-40°C to 105°C (Tj)	0°C to 90°C (Tj)

Table 1.3 i.MX 6ULL Processor Resource Comparison

## 2. Hardware Characteristics

### 2.1 i.MX 6ULL Characteristics

#### 2.1.1 i.MX 6ULL Overview

The i.MX 6ULL is a high performance, ultra efficient processor family with NXP’s advanced implementation of the single ARM Cortex®-A7 core. It operates at speeds up to 900 MHz. i.MX 6ULL includes integrated power management module that reduces the complexity of external power supply and simplifies the power sequencing. Each processor in this family provides various memory interfaces, including LPDDR2, DDR3, DDR3L, Raw and Managed NAND flash, NOR flash, eMMC, Quad SPI, and a wide range of other interfaces for connecting peripherals, such as WLAN, Bluetooth™, GPS, displays, and camera sensors.

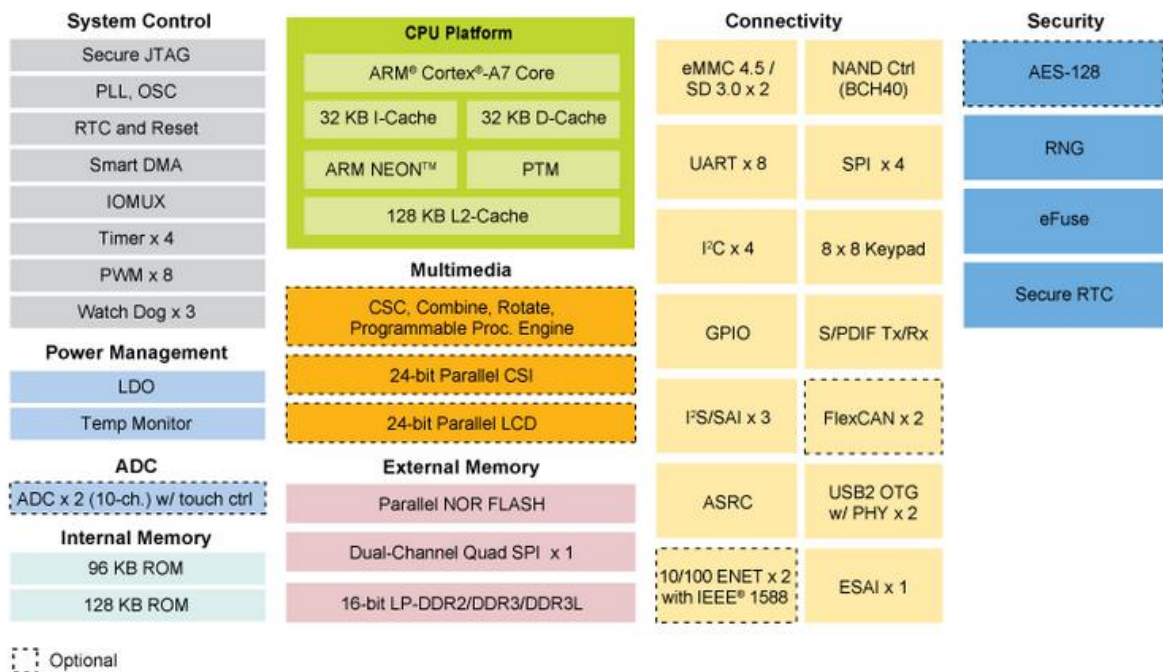

Figure 2.1 i.MX 6ULL Block Diagram



## 2.1.2 i.MX 6ULL Features

- ARM® Cortex®-A7 core up to 900 MHz, 128 KB L2 cache
- Parallel LCD Display up to WXGA (1366x768)
- 8/10/16/24-bit Parallel Camera Sensor Interface
- Electrophoretic display controller support direct-driver for E-Ink EPD panel, with up to 2048x1536 resolution at 106 Hz
- 16-bit LP-DDR2, DDR3/DDR3L
- 8/16-bit Parallel NOR FLASH / PSRAM
- Dual-channel Quad-SPI NOR FLASH
- 8-bit Raw NAND FLASH with 40-bit ECC
- 2x MMC 4.5/SD 3.0/SDIO Port
- 2x USB 2.0 OTG, HS/FS, Device or Host with PHY
- Audio Interfaces include 3x I2S/SAI, S/PDIF Tx/Rx
- 2x 10/100 Ethernet with IEEE 1588
- 2x 12-bit ADC, up to 10 input channel total, with resistive touch controller (4-wire/5-wire)
- Partial PMU Integration
- Security Block: TRNG, Crypto Engine (AES with DPA, TDES/SHA/RSA), Secure Boot
- 14x14 289 MAPBGA 0.8mm pitch

## 2.1.3 i.MX 6UL Overview

The i.MX 6UL is a high performance, ultra efficient processor family with NXP's advanced implementation of the single ARM Cortex®-A7 core. It operates at speeds of up to 629 MHz. i.MX 6UL includes integrated power management module that reduces the complexity of external power supply and simplifies the power sequencing. Each processor in this family provides various memory interfaces, including LPDDR2, DDR3, DDR3L, Raw and Managed NAND flash, NOR flash, eMMC, Quad SPI, and a wide range of other interfaces for connecting peripherals, such as WLAN, Bluetooth™, GPS, displays, and

camera sensors.

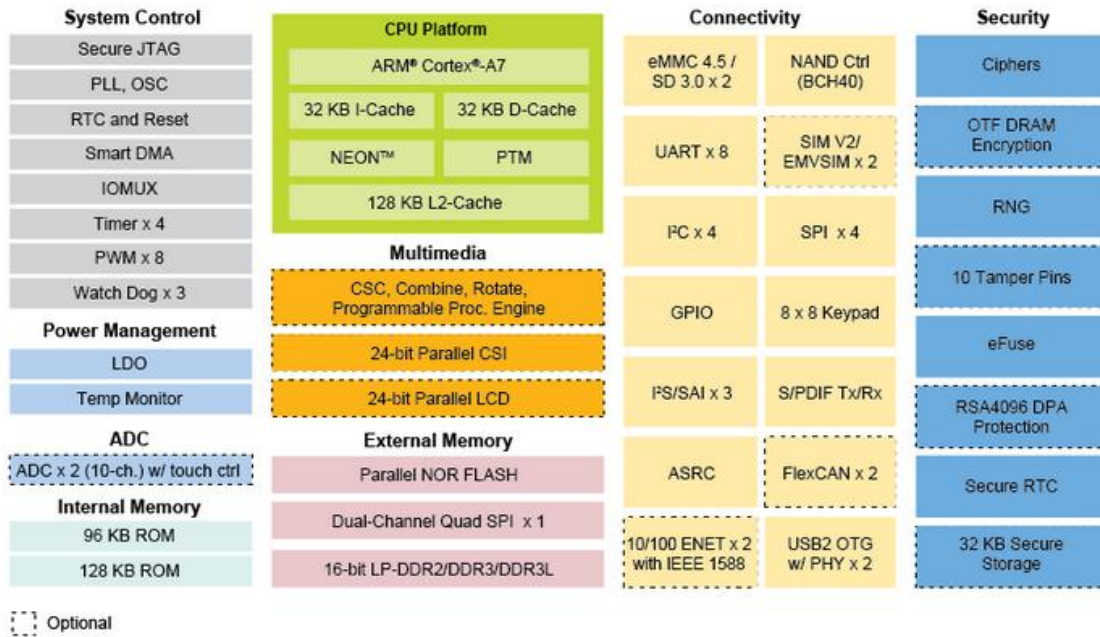

Figure 2.2 i.MX 6UL Block Diagram

## 2.1.4 i.MX 6UL Features

- ARM® Cortex®-A7 @ 696 MHz, 128 KB L2 cache
- Parallel LCD Display up to WXGA (1366x768)
- 8/10/16/24-bit Parallel Camera Sensor Interface
- 16-bit LP-DDR2, DDR3/DDR3L
- 8/16-bit Parallel NOR FLASH / PSRAM
- Dual-channel Quad-SPI NOR FLASH
- 8-bit Raw NAND FLASH with 40-bit ECC
- 2x MMC 4.5/SD 3.0/SDIO Port
- 2x USB 2.0 OTG, HS/FS, Device or Host with PHY
- Audio Interfaces include 3x I2S/SAI, S/PDIF Tx/Rx
- 2x 10/100 Ethernet with IEEE 1588
- 2x 12-bit ADC, up to 10 input channel total, with resistive touch controller (4-wire/5-wire)
- Partial PMU Integration

- Security Block: TRNG, Crypto Engine (AES with DPA, TDES/SHA/RSA), Tamper Monitor, Secure Boot, SIMV2/EVMSIM X 2, OTF DRAM
- Encryption, PCI4.0 pre-certification
- 14x14 289MAPBGA 0.8mm pitch

## 2.2 Board Resource

MYC-Y6ULX CPU module is compatible with i.MX 6UL and i.MX 6ULL series processors. The board with high-speed circuit board design, which is integrated processor, DDR, NAND Flash, eMMC, Ethernet PHY and power management circuit on the PCB size of 37 x 39 mm.

Please refer to the below Figure 2.3 for detail.

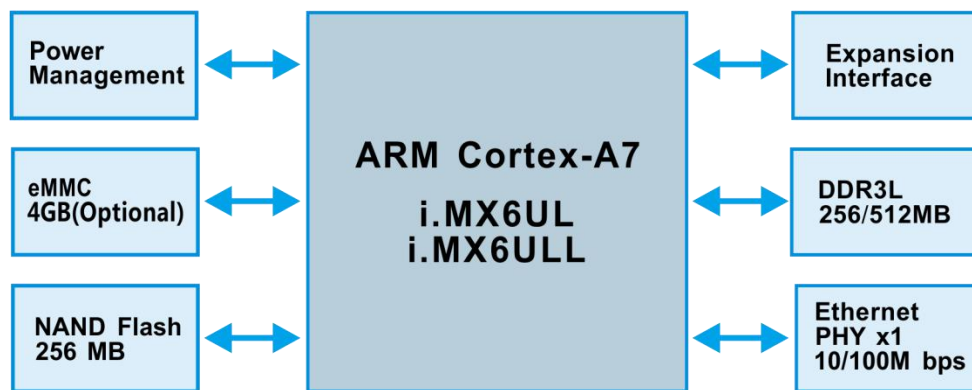

Figure 2.3 Function Block Diagram of MYC-Y6ULX

- **Processor**
  - MCIMX6G2CVM05AB\MCIMX6Y2DVM05AA
- **Memory**
  - 256MB/512MB DDR3L
  - 4GB eMMC Flash (Reuse with NAND Flash)
  - 256MB NAND Flash (Reuse with eMMC)
- **Peripherals**

- 10/100 Ethernet PHY
- Expansion connector (Up to 97 x GPIOs)

## 2.3 Expansion Connector Resource

The expansion connector of MYC-Y6ULX has 140 pins, which contain rich peripheral resources.

Please refer to below for expansion connector resource.

- 2 x Ethernet
- Up to 97 x GPIO
- Up to 8 x UART
- Up to 4 x I2C
- 2 x CAN
- Up to 4 x SPI
- 8 x ADC Input
- Up to 8x PWM
- 3 x I2S
- 1 x Camera
- 1 x JTAG
- 1 x 24 bit LCD

The list is showing the maximum number of the specific interface possible, but due to the reused pin definition, customer will need to refer the pin definition for signal configuration.

### 3. Interfaces

#### 3.1 Pin Assignment

Please refer to the MYC-Y6ULX pin assignment in following figure 3.1.

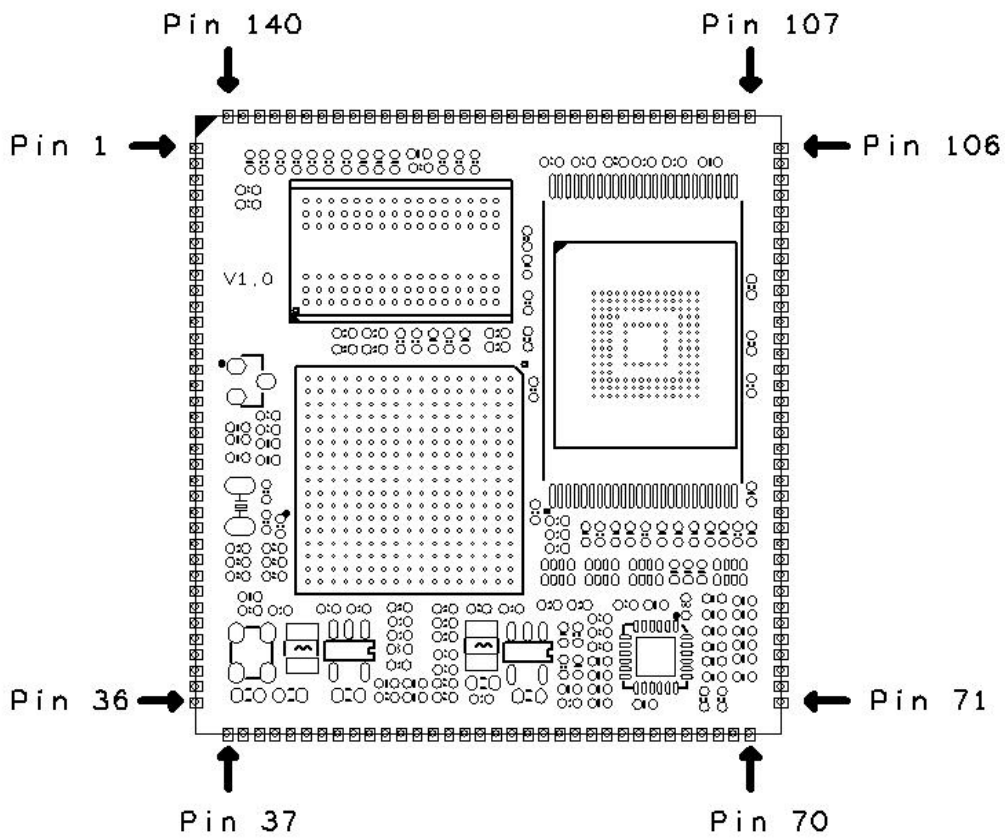

Figure 3.1 Pin assignment

#### 3.2 Pin List

Please refer to the Pin-Out description document MYC-Y6ULX Pin-list, which is provided in the CD-ROM of the development kit.

## 4. Hardware Design

### 4.1 Power Supply

i.MX6UL/6ULL includes integrated power management module that reduces the complexity of external power supply and simplifies the power sequencing. It is easy to implement the power supply unit via discrete device.

Based on the datasheet of i.MX6UL/6ULL, the CPU power can be summarized to 5 power rails, which are as below Table 4.1.

Item	Voltage	Power Rail
1	3.3V	VDD_HIGH_IN, NVCC_xxx, VDDA_ADC_3P3
2	1.2V	VDD_SOC_IN
3	1.35V	NVCC_DRAM
4	3.0V	VDD_SNVS_IN
5	5V	USB_OTGx_VBUS

Table 4.1 i.MX6 ULL Power rail

MYC-Y6ULX CPU module is designed to offer power via discrete device circuit instead of the power management IC. Please refer to below power tree for detail.

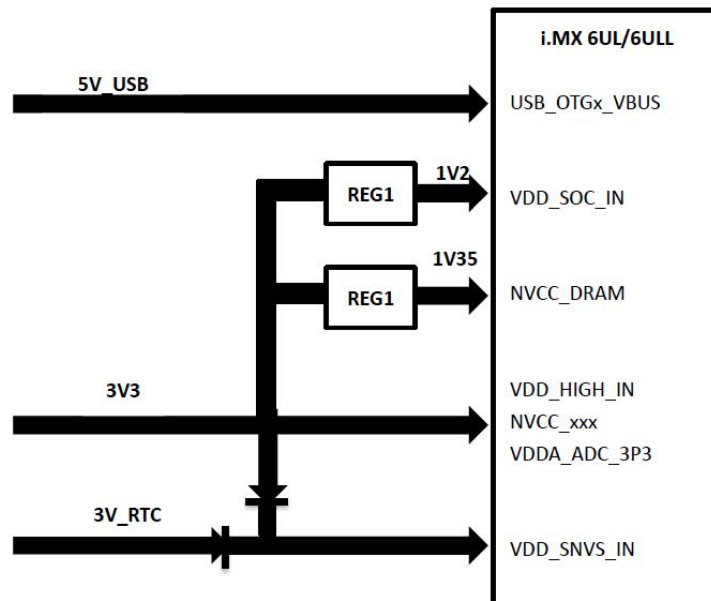

Figure 4.1 MYC-Y6ULX Power Tree

## 4.2 Clock Resources

MYC-Y6ULX CPU module includes two CPU clocks,

- 24 Mhz CPU main clock (Y1)
- 32.768 Khz CPU RTC clock(Y2)

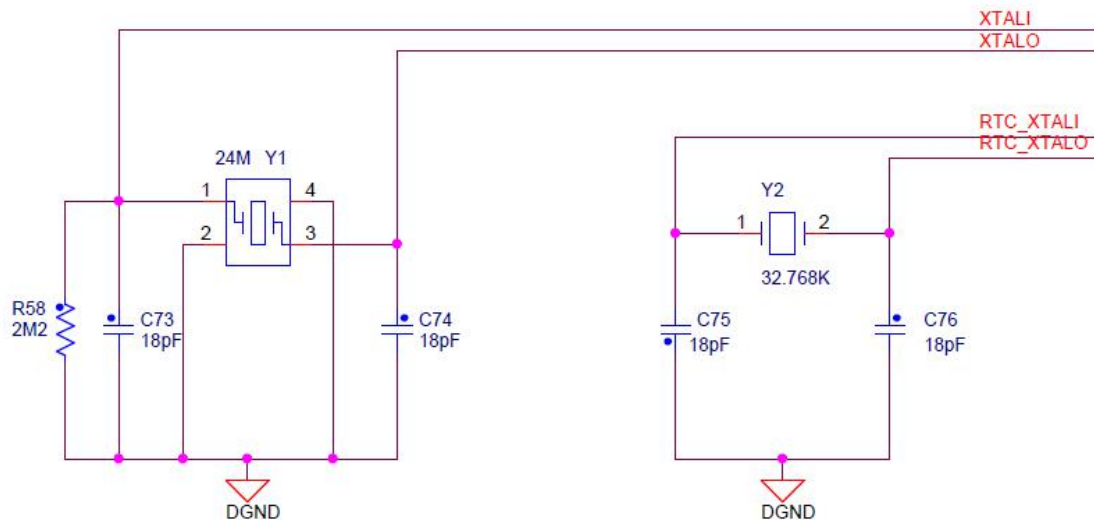

Figure 4.2 Clock Resources

## 4.3 DDR3L SDRAM

MYC-Y6ULX CPU module is equipped with a DDR3L SDRAM Memory. The working frequency is up to 400MHZ with bandwidth of 16bit, and the DDR size is up to 1G byte. Different part number of the MYC-6ULX has different DDR3L chip, please refer to the part number as bellow,

- MYC-Y6ULG2-256N256D-50-I  
The part number is MT41K128M16JT-125 IT:K from Micron.
- MYC-Y6ULY2-256N256D-50-C  
The part number is K4B2G1646F-BYK0 from Samsung
- MYC-Y6ULY2-4E512D-50-C  
The part number is MT41K256M16TW-107:P from Micron.

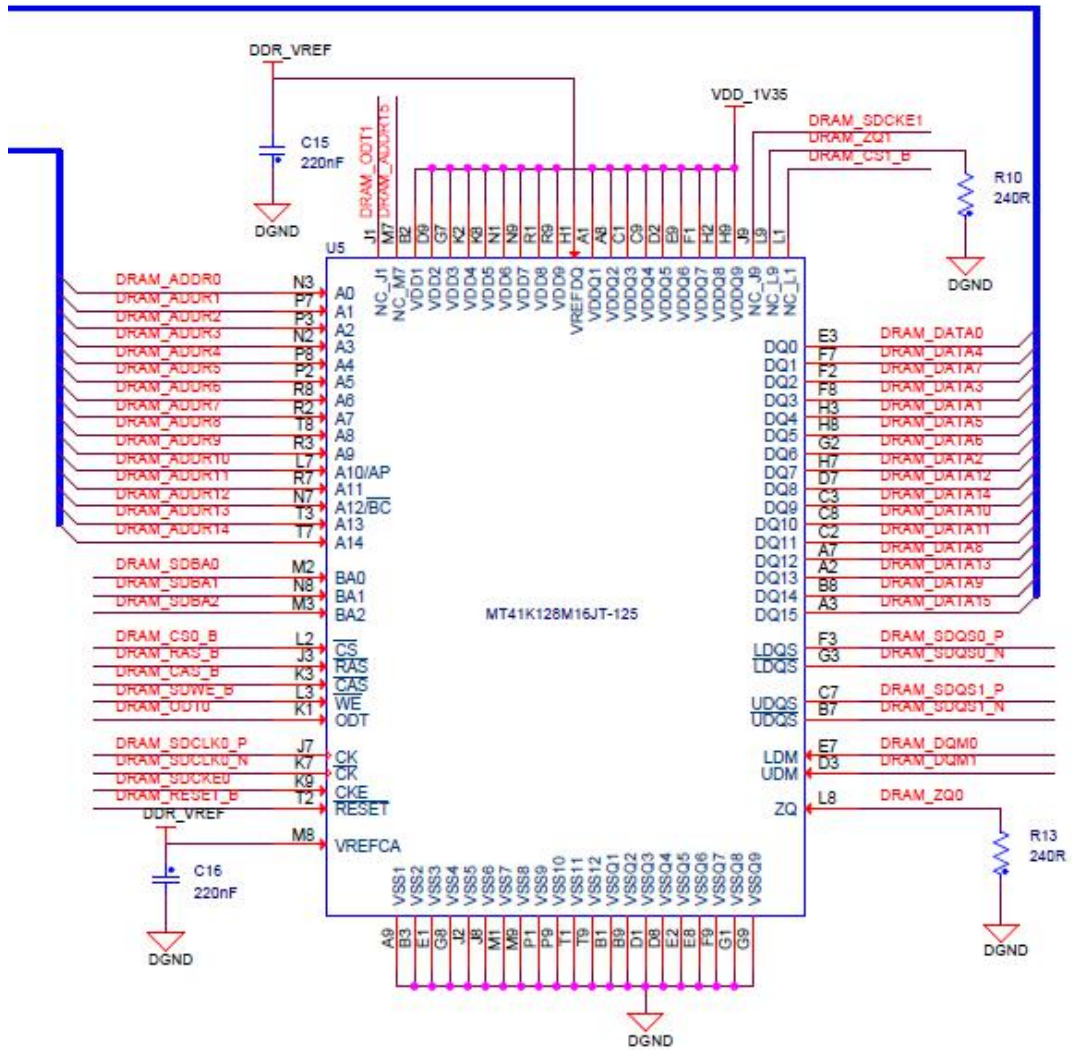

Figure 4.3 DDR3L SDRAM

### 4.4 eMMC Memory

MYC-Y6ULX CPU module is designed to support both NAND Flash and eMMC, but they are on same place on the PCB. We can only choose one of them in the application. The eMMC Memory is connected to SD2 port of processor (8bit bandwidth).A reference design of using 4GB eMMC (Micron, MTFC4GACAJCN-1M WT) as below.



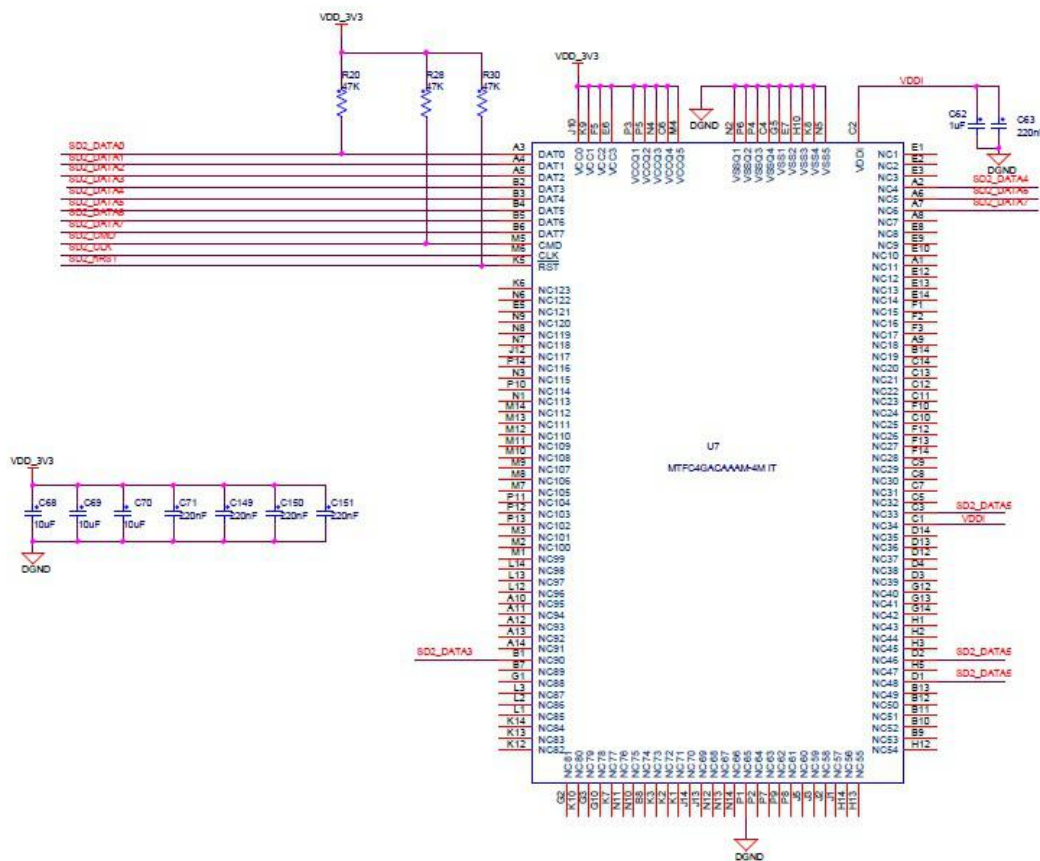

Figure 4.4 eMMC Memory

## 4.5 NAND Flash Memory

MYC-Y6ULX CPU module is designed to support both NAND Flash and eMMC, but they are on same place on the PCB. We can only choose one of them in the application. One NAND Flash with 256MB is connected to the GPMI controller of the processor in default. The part number is MT29F2G08ABAEAWP from Micron. It can be used to store the system booting code and other information.

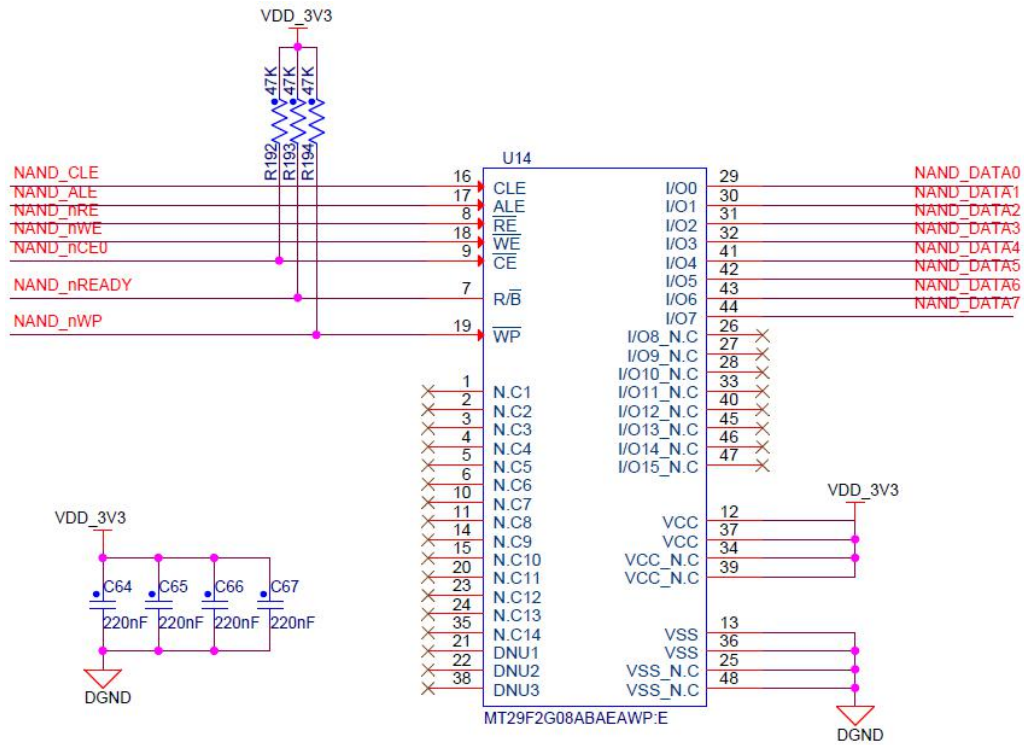

Figure 4.5 NAND Flash

## 4.6 Ethernet

MYC-Y6ULX CPU module is equipped with an ethernet PHY with part number of LAN8720A from Microchip. The PHY address of MDIO bus is 0. Please refer to the schematic of the Ethernet of the board as below. It greatly helps to simplify the base board design and enhance the reliability of Ethernet circuit.

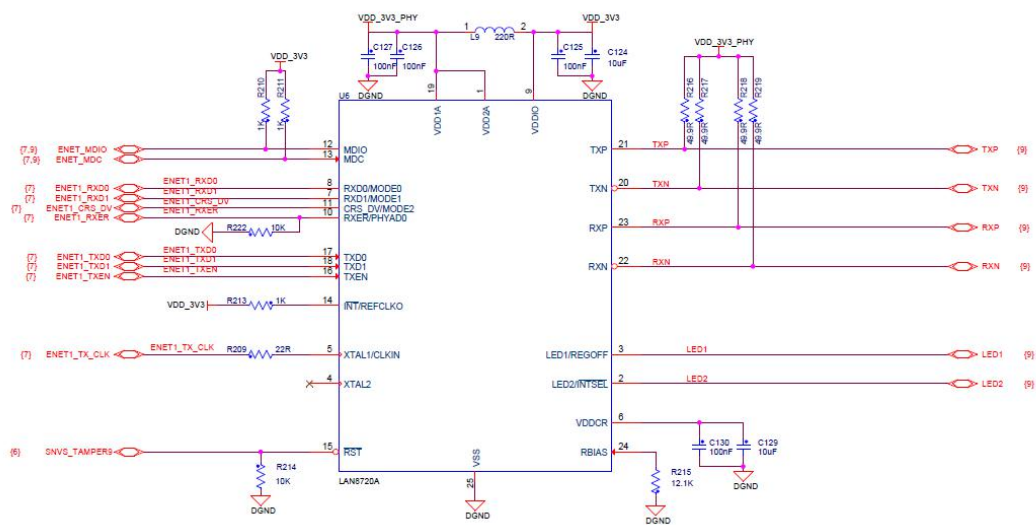

Figure 4.6 Ethernet

## 5. Electronic Characteristics

### 5.1 Operating Temperature

Application Scenarios	Parameter				Des.
	MIN	Nor.	Max	Unit	
Commercial Level	0	—	+70	°C	—
Industrial Level	-40	—	+85	°C	—

Table 5.1 Operating Temperate

### 5.2 Power Supply Characteristics

Item	Label	Parameter				Description
		MIN	Normal	MAX	Unit	
System Voltage	3.3V	3	3.3	3.6	V	Power In
System Current	I3.3V	---	0.25	---	A	
RTC Voltage	VDD_BAT	2.4	--	3.6	V	RTC Power In
RTC Current	IVDD_BAT		220		uA	

Table 5.2 Power Supply Characteristics

## 5.3 GPIO DC Characteristics

Item	Label	Parameter				Description
		MIN	Normal	MAX	Unit	
Input High Voltage	V <sub>IH</sub>	2.3	--	3.3	V	--
Input Low Voltage	V <sub>IL</sub>	0	--	0.99	V	--
Output high Voltage	V <sub>OH</sub>	3.15	---	--	V	--
Output Low Voltage	V <sub>OL</sub>	--	--	0.15	V	--

Table 5.3 GPIO DC Characteristics

## 6. Mechanical Characteristics

### 6.1 Mechanical Data

- ◆ PCB Layers  
8 Layers PCB, Immersion Gold Process, Lead-Free
- ◆ Mechanical  
37x39x3mm

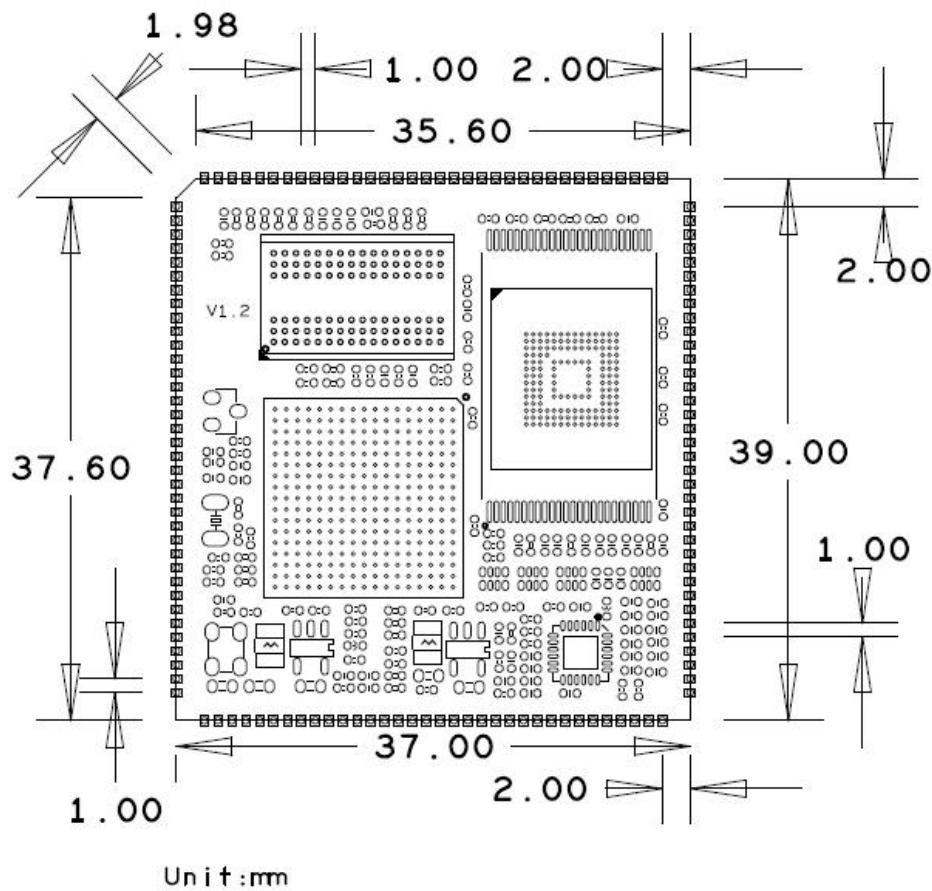

Figure 6.1 Mechanical Information of MYC-Y6ULX

For more details about the board, please refer to the DXF file.

### 6.2 Recommender PCB Footprint

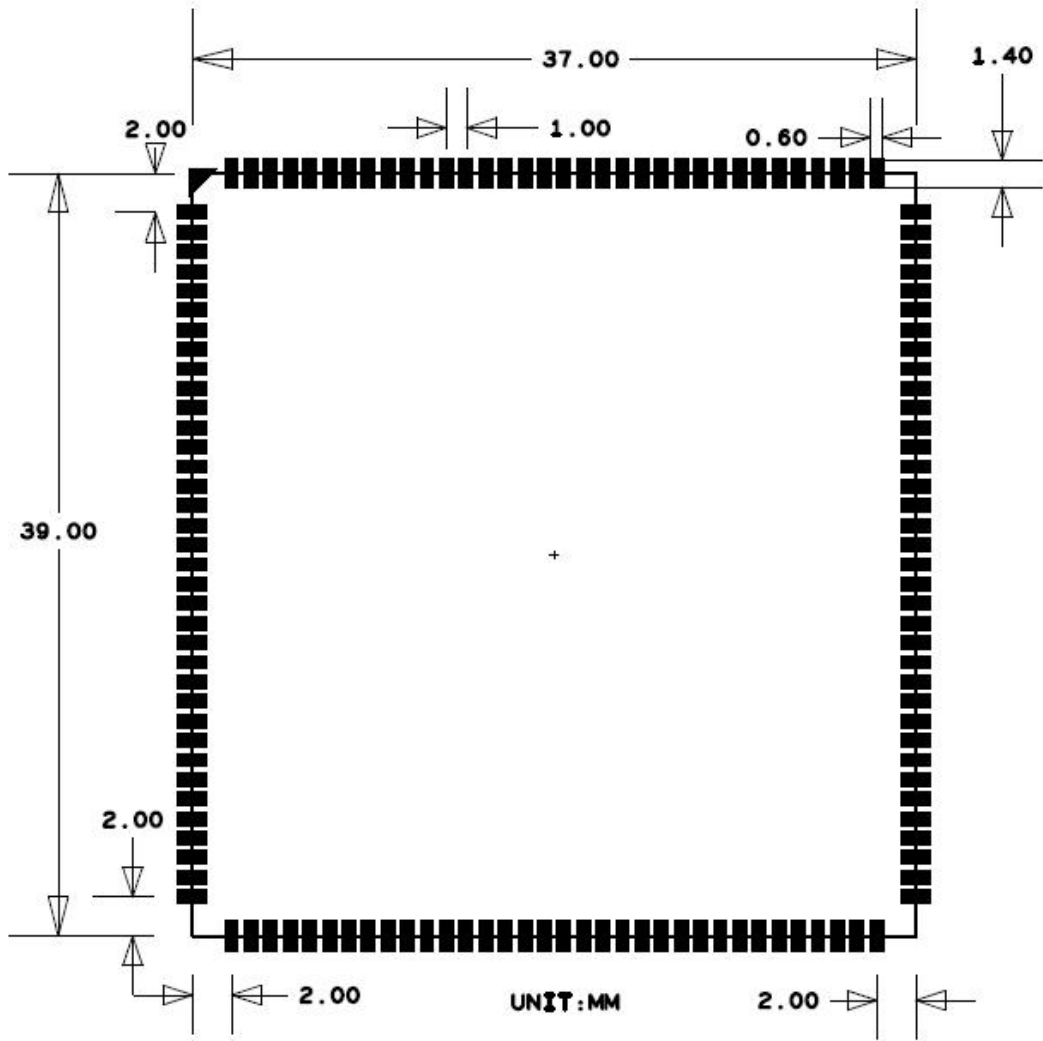

Figure 6.2 Recommender PCB Footprint of MYC-Y6ULX

## 7. Development Kits

The MYD-Y6ULX Development Board is a complete evaluation platform for NXP's i.MX6UL and i.MX6ULL ARM Cortex-A7 processor. The MYD-Y6ULX development boards consist of a CPU module MYC-Y6ULX and a base board MYB-Y6ULX. It is designed to be a complete design reference for embedded developing on the i.MX6UL/6ULL processor and designs based on MYD-Y6ULX CPU Module.

For more information, please go to the website: <http://www.myirtech.com>



Figure 7.1 MYD-Y6ULX



## 8. Schematic design information

### 8.1 Boot information

The boot process begins at Power On Reset (POR) where the hardware reset logic forces the ARM core to begin execution starting from the on-chip boot ROM. Boot ROM code uses the state of the internal register BOOT\_MODE[1:0] as well as the state of various eFUSES and/or GPIO settings to determine the boot flow behavior of the device.

BOOT\_MODE is initialized by sampling the BOOT\_MODE0 and BOOT\_MODE1 inputs on the rising edge of POR\_B, These values decide the startup mode of the CPU. Please refer the boot mode as bellow.

**Table 8-1. Boot MODE Pin Settings**

BOOT_MODE[1:0]	Boot Type
00	Boot From Fuses
01	Serial Downloader
10	Internal Boot
11	Reserved

Table 8.1 Boot Mode Pin setting

- **Boot From Fuses Mode:** The Boot information is readed from internal Fuses, NXP recommends the use of this mode in mass production.
- **Serial Downloader Mode:** The Serial Downloader provides a means to download a Program Image to the chip over USB and UART serial connection.
- **Internal Boot Mode:** The Boot information can be readed from the GPIOs, NXP recommended the use of this mode for development. Customers don't have to write Fuse (one-time programming), and the startup device can be change flexibly in this mode. Many users are directly used for production.

The BOOT\_MODE0 and BOOT\_MODE1 pins have been pulled up to 3V3 vas the 47K resistor in the MYC-Y6ULX. When you need to set the two pins to low level, use the 1K resistance to pull down to the ground.

When CPU is set to Internal Boot Mode, CPU will read the level state of the LCD\_DATA0

to LCD\_DATA23 pins to determine the boot device when power on reset. In the MYC-Y6ULX core board, these pins have been tied to the right level. Only two pins need to be processed, when design a carrier board. Please refer the boot device configure as bellow.

Boot device configure for eMMC core board,

Device Pins	eMMC(SDIO2)Boot	SDIO1 Boot
LCD_DATA5	Floating	Pull down using 1K resister
LCD_DATA11	Floating	Pull down using 1K resister

Table 8.2 Boot device configure for EMMC version

Boot device configure for NAND flash core board,

Device Pins	NAND Flash	SDIO1 Boot
LCD_DATA6	Pull down using 1K resister	Floating
LCD_DATA7	Floating	Pull down using 1K resister

Table 8.3 Boot device configure for NAND Flash version

## 8.2 Base system design reference

The base system of the MYC-Y6ULX CPU Module is simple, not need the external clock, the reset pin has been handled properly within the module. Customers just supply a single 3v3 power (recommender 500 mA) and set up the boot configure correctly. The CPU module will work. Please refer the design on figure 8.1 and figure 8.2.

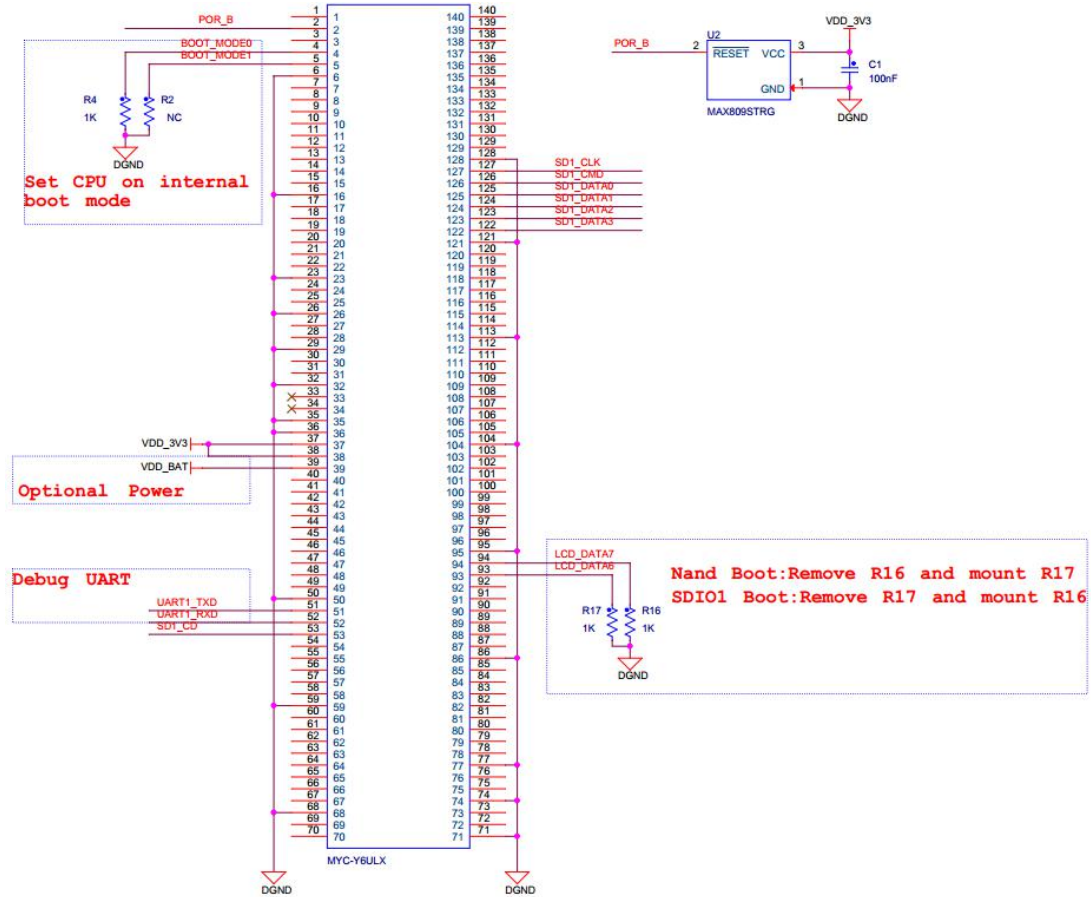

Figure 8.1 Base system for NAND Flash version

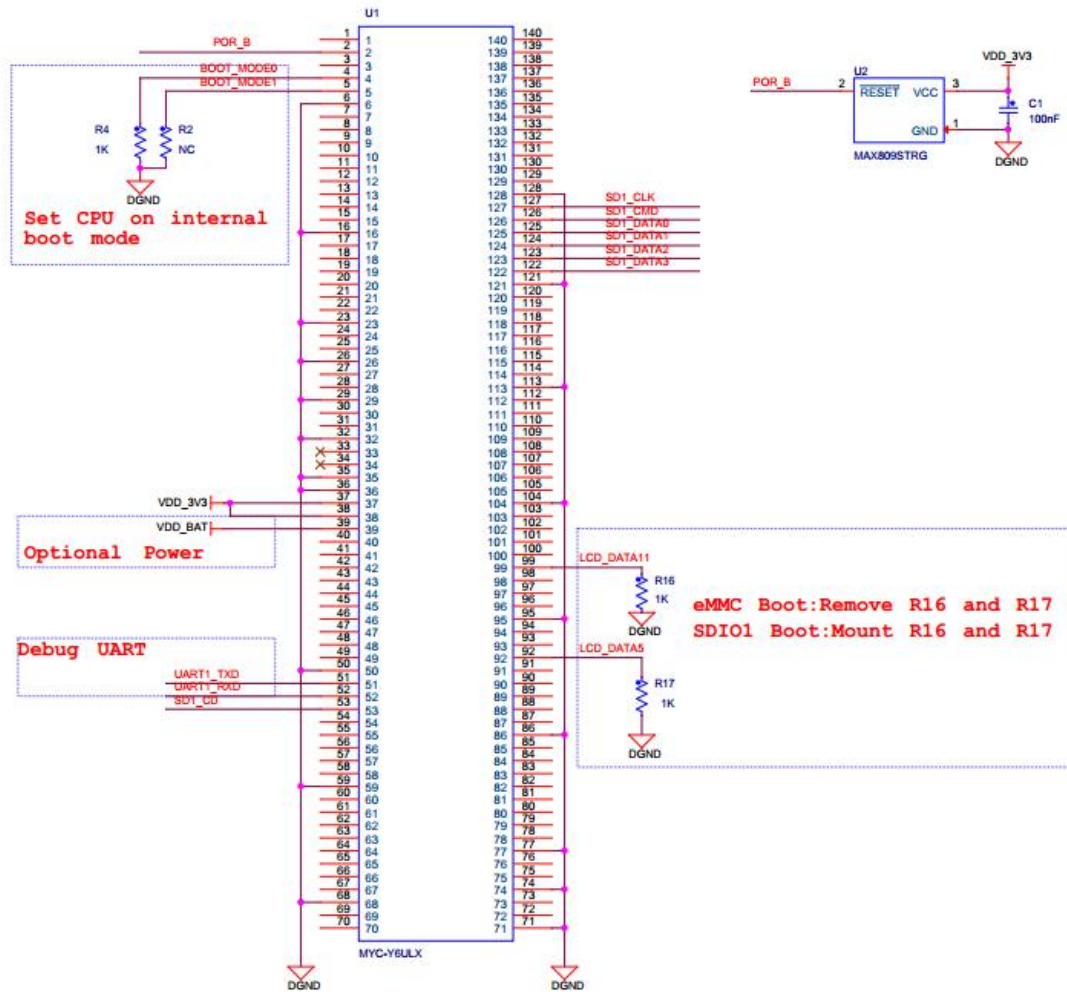

Figure 8.2 Base system for eMMC version

### 8.3 Design advice

- LCD\_DATA0-LCD\_DATA23 are the boot configuration pins, which has been handled properly within the module. It is not recommended that pull these pins to ground or power, so as not to affect the boot of the module.
- When designing the power supply, it must be ensured that the CPU main power supply appears earlier than the peripheral
- VDD\_BAT is the LP power domain of the CPU. It has been connected to 3.3V on the CPU module. If customers do not need to use this power, you can leave it unconnected.

## Appendix 1 Warranty & Technical Support Services

**MYIR Tech Limited** is a global provider of ARM hardware and software tools, design solutions for embedded applications. We support our customers in a wide range of services to accelerate your time to market.

MYIR is an ARM Connected Community Member and work closely with ARM and many semiconductor vendors. We sell products ranging from board level products such as development boards, single board computers and CPU modules to help with your evaluation, prototype, and system integration or creating your own applications. Our products are used widely in industrial control, medical devices, consumer electronic, telecommunication systems, Human Machine Interface (HMI) and more other embedded applications. MYIR has an experienced team and provides custom design services based on ARM processors to help customers make your idea a reality.

The contents below introduce to customers the warranty and technical support services provided by MYIR as well as the matters needing attention in using MYIR's products.

### **Service Guarantee**

MYIR regards the product quality as the life of an enterprise. We strictly check and control the core board design, the procurement of components, production control, product testing, packaging, shipping and other aspects and strive to provide products with best quality to customers. We believe that only quality products and excellent services can ensure the long-term cooperation and mutual benefit.

### **Price**

MYIR insists on providing customers with the most valuable products. We do not pursue excess profits which we think only for short-time cooperation. Instead, we hope to establish long-term cooperation and win-win business with customers. So we will offer reasonable prices in the hope of making the business greater with the customers together hand in hand.

### **Delivery Time**

MYIR will always keep a certain stock for its regular products. If your order quantity is less than the amount of inventory, the delivery time would be within three days; if your order quantity is greater than the number of inventory, the delivery time would be always four to six weeks. If for any urgent delivery, we can negotiate with customer and try to supply the goods in advance.

### Technical Support

MYIR has a professional technical support team. Customer can contact us by email ([support@myirtech.com](mailto:support@myirtech.com)), we will try to reply you within 48 hours. For mass production and customized products, we will specify person to follow the case and ensure the smooth production.

### After-sale Service

MYIR offers one year free technical support and after-sales maintenance service from the purchase date. The service covers:

#### 1. Technical support service

- a) MYIR offers technical support for the hardware and software materials which have provided to customers;
- b) To help customers compile and run the source code we offer;
- c) To help customers solve problems occurred during operations if users follow the user manual documents;
- d) To judge whether the failure exists;
- e) To provide free software upgrading service.

However, the following situations are not included in the scope of our free technical support service:

- a) Hardware or software problems occurred during customers' own development;
- b) Problems occurred when customers compile or run the OS which is tailored by themselves;
- c) Problems occurred during customers' own applications development;
- d) Problems occurred during the modification of MYIR's software source code.

#### 2. After-sales maintenance service

The products except LCD, which are not used properly, will take the twelve months free maintenance service since the purchase date. But following situations are not included in the scope of our free maintenance service:

- a) The warranty period is expired;
- b) The customer cannot provide proof-of-purchase or the product has no serial number;
- c) The customer has not followed the instruction of the manual which has caused the damage the product;
- d) Due to the natural disasters (unexpected matters), or natural attrition of the components, or unexpected matters leads the defects of appearance/function;

- e) Due to the power supply, bump, leaking of the roof, pets, moist, impurities into the boards, all those reasons which have caused the damage of the products or defects of appearance;
- f) Due to unauthorized weld or dismantle parts or repair the products which has caused the damage of the products or defects of appearance;
- g) Due to unauthorized installation of the software, system or incorrect configuration or computer virus which has caused the damage of products.

**Warm tips:**

- 1) MYIR does not supply maintenance service to LCD. We suggest the customer first check the LCD when receiving the goods. In case the LCD cannot run or no display, customer should contact MYIR within 7 business days from the moment get the goods.
- 2) Please do not use finger nails or hard sharp object to touch the surface of the LCD.
- 3) MYIR suggests user purchasing a piece of special wiper to wipe the LCD after long time use, please avoid clean the surface with fingers or hands to leave fingerprint.
- 4) Do not clean the surface of the screen with chemicals.
- 5) Please read through the product user manual before you using MYIR's products.
- 6) For any maintenance service, customers should communicate with MYIR to confirm the issue first. MYIR's support team will judge the failure to see if the goods need to be returned for repair service, we will issue you RMA number for return maintenance service after confirmation.

### 3. Maintenance period and charges

- a) MYIR will test the products within three days after receipt of the returned goods and inform customer the testing result. Then we will arrange shipment within one week for the repaired goods to the customer. For any special failure, we will negotiate with customers to confirm the maintenance period.
- b) For products within warranty period and caused by quality problem, MYIR offers free maintenance service; for products within warranty period but out of free maintenance service scope, MYIR provides maintenance service but shall charge some basic material cost; for products out of warranty period, MYIR provides maintenance service but shall charge some basic material cost and handling fee.

#### 4. Shipping cost

During the warranty period, the shipping cost which delivered to MYIR should be responsible by user; MYIR will pay for the return shipping cost to users when the product is repaired. If the warranty period is expired, all the shipping cost will be responsible by users.

#### 5. Products Life Cycle

MYIR will always select mainstream chips for our design, thus to ensure at least ten years continuous supply; if meeting some main chip stopping production, we will inform customers in time and assist customers with products updating and upgrading.

#### Value-added Services

1. MYIR provides services of driver development base on MYIR's products, like serial port, USB, Ethernet, LCD, etc.
2. MYIR provides the services of OS porting, BSP drivers' development, API software development, etc.
3. MYIR provides other products supporting services like power adapter, LCD panel, etc.
4. ODM/OEM services.



#### MYIR Tech Limited

Room 04, 6th Floor, Building No.2, Fada Road,  
Yunli Intelligent Park, Bantian, Longgang District,  
Shenzhen, Guangdong, China 518129

Support Email: [support@myirtech.com](mailto:support@myirtech.com)

Sales Email: [sales@myirtech.com](mailto:sales@myirtech.com)

Phone: +86-755-22984836

Fax: +86-755-25532724

Website: [www.myirtech.com](http://www.myirtech.com)